

Technical data sheet

Equipotential busbar 1809 for concealed mounting

Item number: 5015065

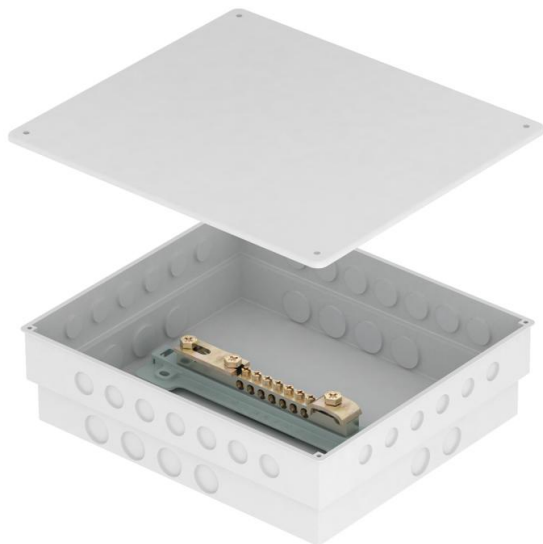

- Mounted equipotential busbar 1809 (without cover hood) in concealed housing
- Pre-marked concealed housing for inserting required cables and cover
- Contact strip made of nickel-plated brass
- Bolts and crossbar made of electrogalvanised steel
- Capable of carrying lightning current 100 kA (10/350)

Connection options:

- 7x cables up to 25 mm²
- 1 round conductor Rd 8–10
- 1 flat conductor up to FL 30 or round conductor Rd 8–10



CuZn 37 Brass

Master data

Item number	5015065
Type	1809 UP
Description 1	Equipotential busbar
Description 2	in box for concealed mounting
Manufacturer	OBO
Dimension	50x5mm
Material	Brass
Smallest sales unit	1
Unit of quantity	Piece
Weight	74.5 kg
Weight unit	kg/100 pc.

Technical data sheet

Equipotential busbar 1809 for concealed mounting

Item number: 5015065



Dimensions

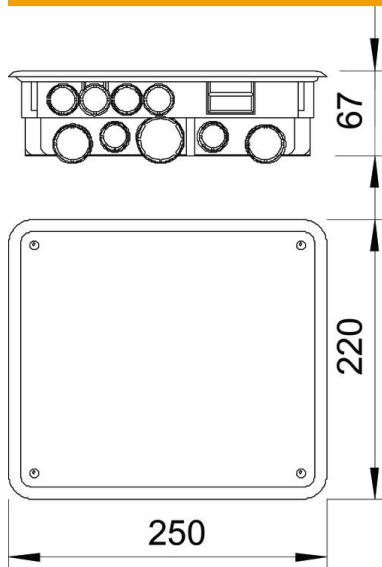

Length	250 mm
Width	220 mm
Height	67 mm

Technical data

Quantity of flat conductor connections up to 30 mm	1
Quantity of flat conductor connections up to 40 mm	0
Quantity of cable connections up to 16 mm ² , rigid	0
Quantity of cable connections up to 25 mm ² , rigid	7
Quantity of cable connections up to 6 mm ² , rigid	0
Quantity of cable connections up to 95 mm ² , rigid	0
Quantity of round conductor connections 10 mm	0
Quantity of round conductor connections 8 mm	0
Quantity of round conductor connections 8-10 mm	1
Quantity of round conductor connections, total	1
Version for	In the housing
Type	Fixed structure
Insulator	yes
Surface of the terminal	Electrogalvanised
Surface of the contact rail	Nickel-plated
Material of the terminal	Steel
Material of the contact rail	Brass